

**CHIORINO**<sup>®</sup>  
1906

*Passion for belting*

**HP** *COMPACT*<sup>®</sup>  
**DRIVE**

Partner for  
food conveying solutions

Homogeneous and Drive belts

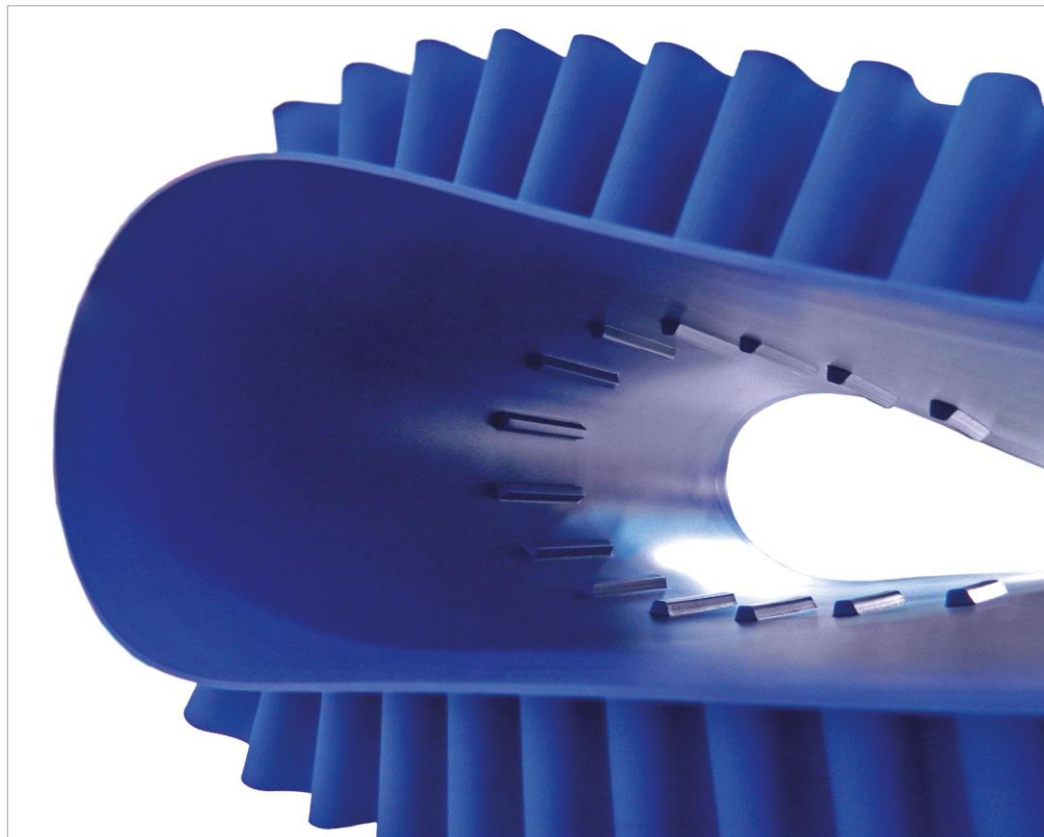
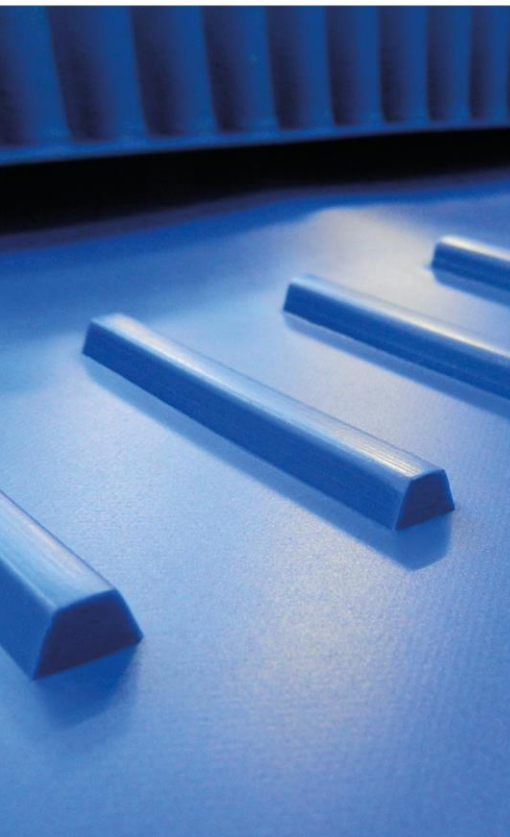

TECHNICAL MANUAL



# Index

	Page
<b>1. Introduction</b>	<b>4</b>
1.1 Product advantages	5
<b>2. Technical data</b>	<b>6</b>
2.1 Production program	6
2.2 Chiorino standard sprockets / pulleys	7
<b>3. Conveyor construction</b>	<b>8</b>
3.1 Classic conveyor design	8
3.2 Guide for the conveyor construction	10
3.2.1 Installation and positioning of the support pulleys	10
3.2.2 Support pulleys	12
3.2.3 Standard belt tensioners	13
3.2.4 Quick release tensioners	13
3.3 Conveyor adjustment	14
3.3.1 Conveyor with flat or supported slidebed adjustment	14
3.3.2 Conveyor with roller slidebed adjustment	14
3.4 "Z" or "Swan neck" conveyor construction	15
3.5 Centre drive conveyor	15
3.6 Belt removal for cleaning	15
<b>4. Sidewalls and transversal profiles</b>	<b>16</b>
4.1 HP® Sidewalls	16
4.2 HP® Transversal profiles	17
<b>5. Endless making</b>	<b>18</b>
5.1 On-site Micro-Z finger joint	18
5.2 Mechanical fastener APF-100	19
5.3 HY-FAST™ Hygienic mechanical fastener	20
<b>6. Belt calculation</b>	<b>21</b>
6.1 Belt calculation for horizontal conveying	22
6.2 Belt calculation for 10° inclination conveying	23
6.3 Belt calculation for 20° inclination conveying	24
6.4 Belt calculation for 30° inclination conveying	25
6.5 Belt calculation for 40° inclination conveying	26
6.6 Example of calculation	27
<b>7. Maintenance and cleaning</b>	<b>28</b>
<i>Annex</i>	
<b>Installation questionnaire</b>	<b>29</b>

## 1. INTRODUCTION

The **HP COMPACT DRIVE**<sup>®</sup> homogeneous conveyor belts are specially designed with a toothed profile on the running side and a smooth conveyor surface.

The toothed profile is placed longitudinally in the central section of the belt or, in case of double-toothed profile, on its sides.

The HP COMPACT DRIVE<sup>®</sup> belts are highly hygienic thanks to their smooth edge surfaces.

The HP COMPACT DRIVE<sup>®</sup> belts are characterized by their conveying system and unique process, as the teeth of the drive pulley fit perfectly with the toothed profile of the running side of the belt.

The return pulley has a smooth surface with a groove that guides the belt.

HP COMPACT DRIVE<sup>®</sup> belts are available in polyurethane (TPU) - **HP** system providing a complete solution for any conveying needs:

- Wide range of different sized pulleys;
- Wide range of transversal profiles and sidewalls.

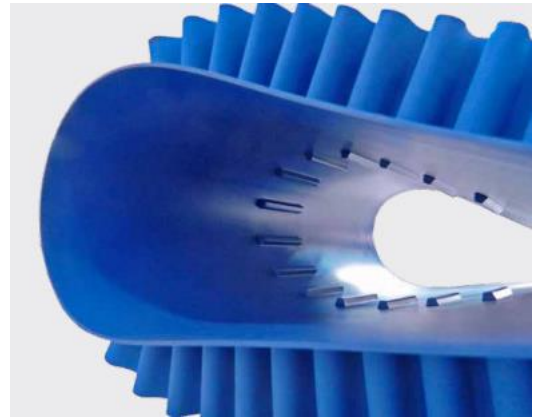

Fig. 1

The HP COMPACT DRIVE<sup>®</sup> belts, thanks to their conveying system, ensure silent running, no vibration, perfect rectilinear advancement, low fitting tensions, modularity of pitches and tailored solutions for conveyor designers.

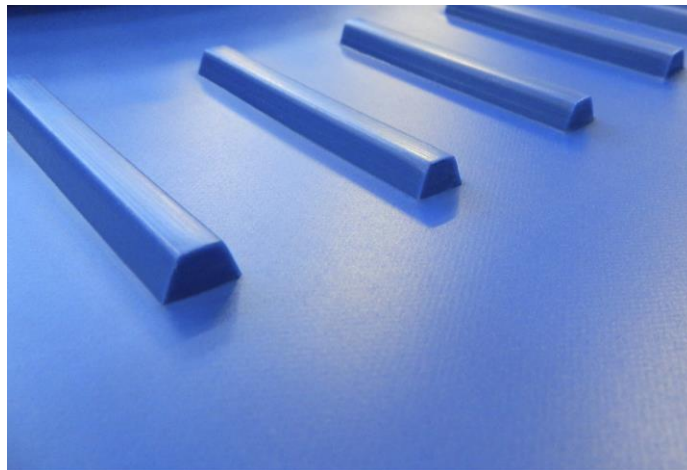

Fig. 2

## 1.1 PRODUCT ADVANTAGES

- **EXTREMELY HYGIENIC AND EASY TO CLEAN**

HP COMPACT DRIVE® belts have an extremely smooth running and conveying surface, very resistant to cuts and abrasions; thereby ensuring fast and effective cleaning of the belt.

- **SYNCHRONOUS DRIVE**

The synchronous drive feature of this belt eliminates slippage and does not generate high tension. This in turn minimizes maintenance and increases the durability of the belt and its overall operating efficiency.

- **PERFECT RECTILINEAR ADVANCEMENT**

The unique design of the teeth allows them to work as a guide for the belt and to ensure the perfect rectilinear advancement. This special feature eliminates the risk of off-tracking, and therefore any potential damage to the same and to the conveyed products.

- **COST REDUCTION**

The HP COMPACT DRIVE® belts are easy to clean, greatly reducing labour and the consumption of chemicals and water. Compared to modular belts, HP COMPACT DRIVE® homogeneous belts minimize production waste.

- **SIMPLE CONVEYOR DESIGN**

The construction of the conveyor is very simple as there is no need to worry about slippages or off-tracking. Any adaptation of your old conveyor is also easily achievable.

- **FOOD SAFETY CERTIFICATION**

The HP COMPACT DRIVE® belts are used throughout the food industry at different stages of processing from the transfer of the product to the packaging lines.

The HP COMPACT DRIVE® belts are suitable for contact with all aqueous, acidic, oily and fatty foods as listed in **EU Regulation 10/2011** and its updates.

For the production of these belts only monomers and additives listed in the **FDA** regulations are used.

Thanks to its very high resistance to abrasion, oils, fats, detergents and the more aggressive cleaning systems, the  product system is particularly suitable for applications requiring compliance with the HACCP system (Hazard Analysis and Critical Control Point) and IFS (International Food Standard).

HP COMPACT DRIVE® belts are **NSF** compliant.

## 2. TECHNICAL DATA

### 2.1 PRODUCTION PROGRAM

**HP COMPACT DRIVE Homogeneous drive belts**



Code	Type	Total thickn. mm	Material	Driving side surface texture	Conveying side surface texture	Pitch mm	Tooth section Bx H mm	Tooth length mm	Pull for 1% elong. N/mm	Min. diam. mm	Temper. resist. °C		Inclined	Swan neck	Trough
											min.	max.			
NA-1359c-D13	HP Compact Drive 20/40 blue	2.0	TPU HP®	smooth	smooth	40	13 x 8	72	8	80	-30	+90			•
NA-1207c-D13	HP Compact Drive 25/40 blue	2.5	TPU HP®	smooth	smooth	40	13 x 8	72	8	80	-30	+90		•	
NA-1294c-D13	HP Compact Drive 25/40 PN blue	2.5	TPU HP®	smooth	PN	40	13 x 8	72	8	80	-30	+90	•	•	
NA-1328c-D13	HP Compact Drive 25/40 RG blue	2.5	TPU HP®	smooth	RG	40	13 x 8	72	8	80	-30	+90	•	•	
NA-1257c-D13	HP Compact Drive 25/40 VL blue	2.5	TPU HP®	smooth	VL	40	13 x 8	72	8	80	-30	+90		•	
NA-1307c-D13	HP Compact Drive 40/40 blue	4.0	TPU HP®	smooth	smooth	40	13 x 8	72	15	80	-30	+90		•	

Table 1

**HP COMPACT DRIVE Homogeneous belts**

Code	Type	Total thickness mm	Material	Driving side surface texture	Conveying side surface texture	Pull for 1% elong N/mm	Min. diam. mm	Temper. resist. °C		Inclined	Swan neck	Trough
								min.	max.			
NA-1359a	HP Compact 20 blue	2.0	TPU HP®	smooth	smooth	8	50	-30	+110			•
NA-1207a	HP Compact 25 blue	2.5	TPU HP®	smooth	smooth	8	50	-30	+110		•	
NA-1294a	HP Compact 25 PN blue	2.5	TPU HP®	smooth	PN	8	50	-30	+110	•	•	
NA-1328a	HP Compact 25 RG blue	2.5	TPU HP®	smooth	RG	8	50	-30	+110	•	•	
NA-1328a RG	HP Compact RG 25blue	2.5	TPU HP®	RG	smooth	8	50	-30	+110		•	
NA-1257a	HP Compact 25 VL blue	2.5	TPU HP®	smooth	VL	8	50	-30	+110		•	
NA-1307a	HP Compact 40 blue	4.0	TPU HP®	smooth	smooth	15	80	-30	+110		•	

Table 2

#### Surface textures



**VL** Velvet

Where a good release is requested, e.g. cheese processing

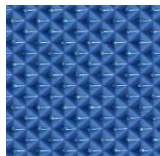

**PN** Pyramid negative

Fruits and vegetables processing in presence of water: makes the release easier

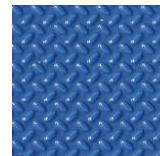

**RG** Rice grain

Frozen meat processing: it increases the coefficient of friction and makes the product positioning easier

## 2.2 CHIORINO STANDARD SPROCKETS / PULLEYS

	Drive pulley pitch 40 mm			Idle pulley			Support pulley		
									
Number of teeth	External Ø <b>A</b> mm	Inner square □ <b>B</b> mm	Width <b>C</b> mm	External Ø <b>D</b> mm	Inner square □ <b>E</b> mm	Width <b>F</b> mm	External Ø <b>G</b> mm	Inner square □ <b>H</b> mm	Width <b>I</b> mm
<b>8</b>	99	40 x 40	80	99	40 x 40	105	99	40 x 40	20
<b>10</b>	125	40 x 40	80	125	40 x 40	105	125	40 x 40	20
<b>12</b>	150	40 x 40	80	150	40 x 40	105	150	40 x 40	20
<b>14</b>	176	40 x 40	80	176	40 x 40	105	176	40 x 40	20
<b>16</b>	201	40 x 40	80	201	40 x 40	105	201	40 x 40	20

Table 3



### 3. CONVEYOR CONSTRUCTION

#### 3.1 CLASSIC CONVEYOR DESIGN

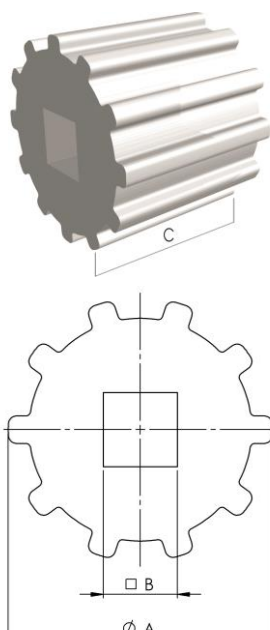
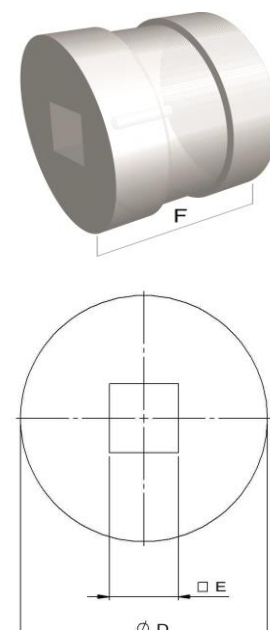
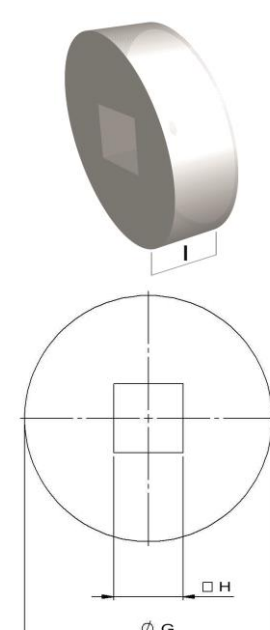
Classic conveyor design – single row of teeth:

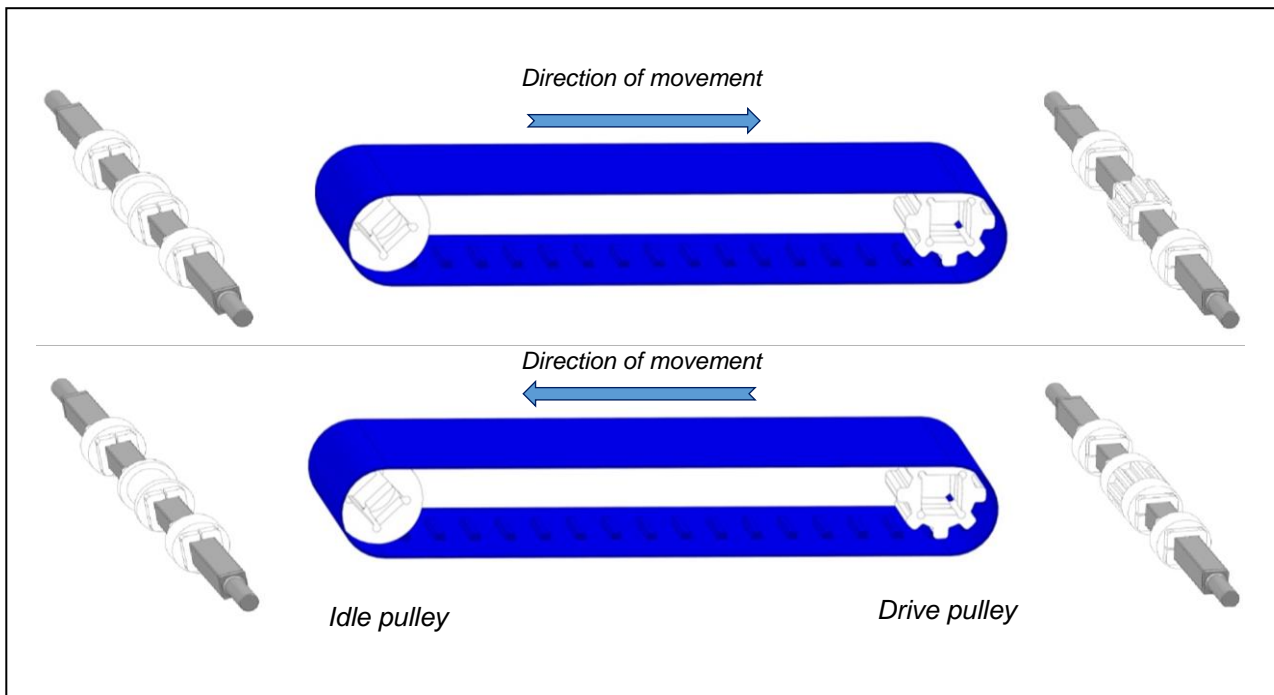

Fig. 3

The main components of a conveyor are:

- 1 Drive pulley
- 1 Slidebed
- 1 Idle pulley with tensioner
- Support pulleys depending upon the width of the belt and the expected load.

In case of anti-clockwise direction, it is necessary to use the support pulleys next to the drive pulley (Fig. 3)



Classic conveyor design – two rows of teeth:

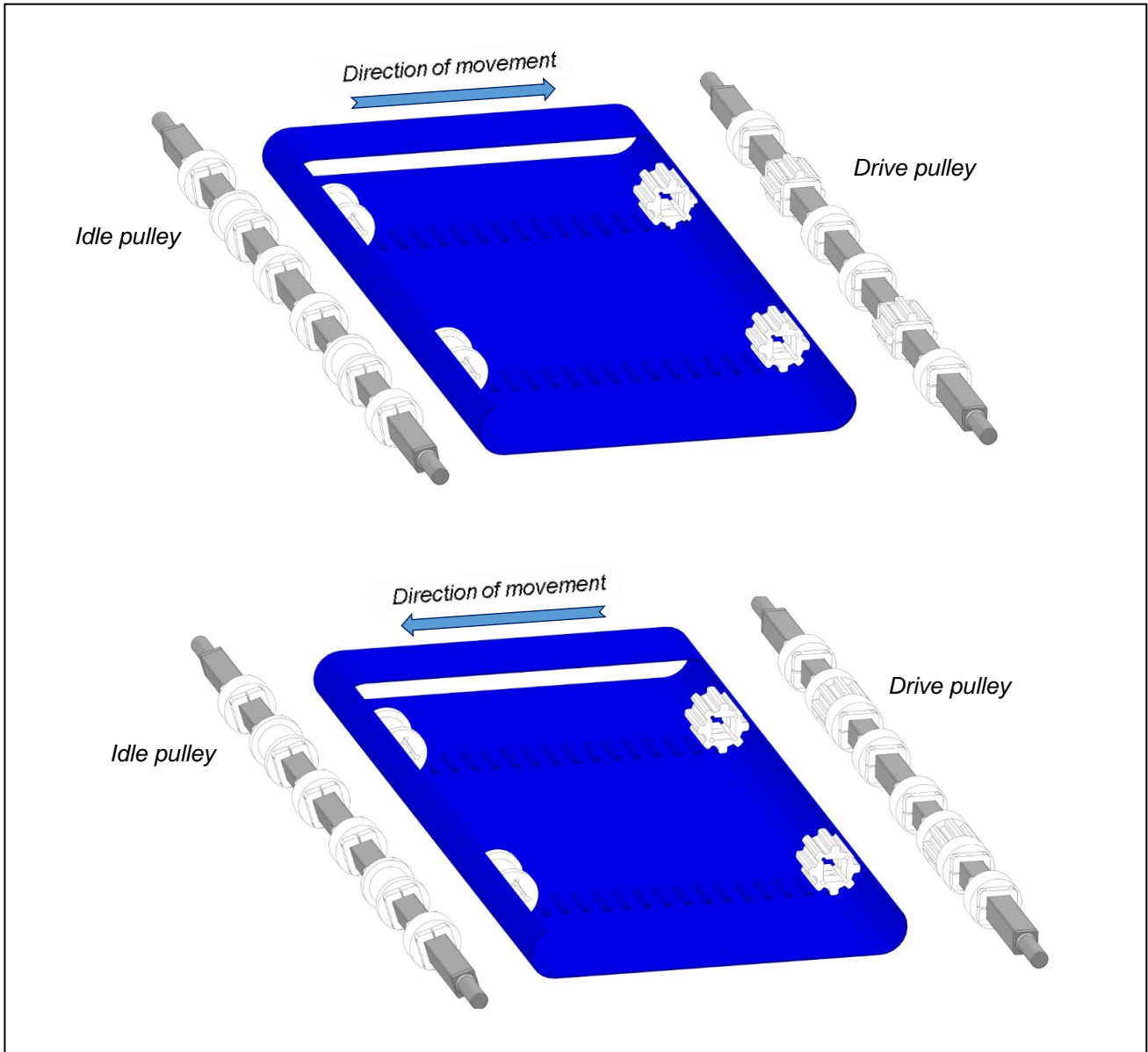

Fig. 4

The main components of a conveyor are:

- 2 Drive pulley
- 1 Slidebed
- 2 Idle pulleys with tensioner
- Support pulleys depending upon the width of the belt and the expected load.

In case of anti-clockwise direction, it is necessary to use the support pulleys next to the pinions (Fig. 4).

### 3.2 GUIDE FOR THE CONVEYOR CONSTRUCTION

#### Recommended dimensions

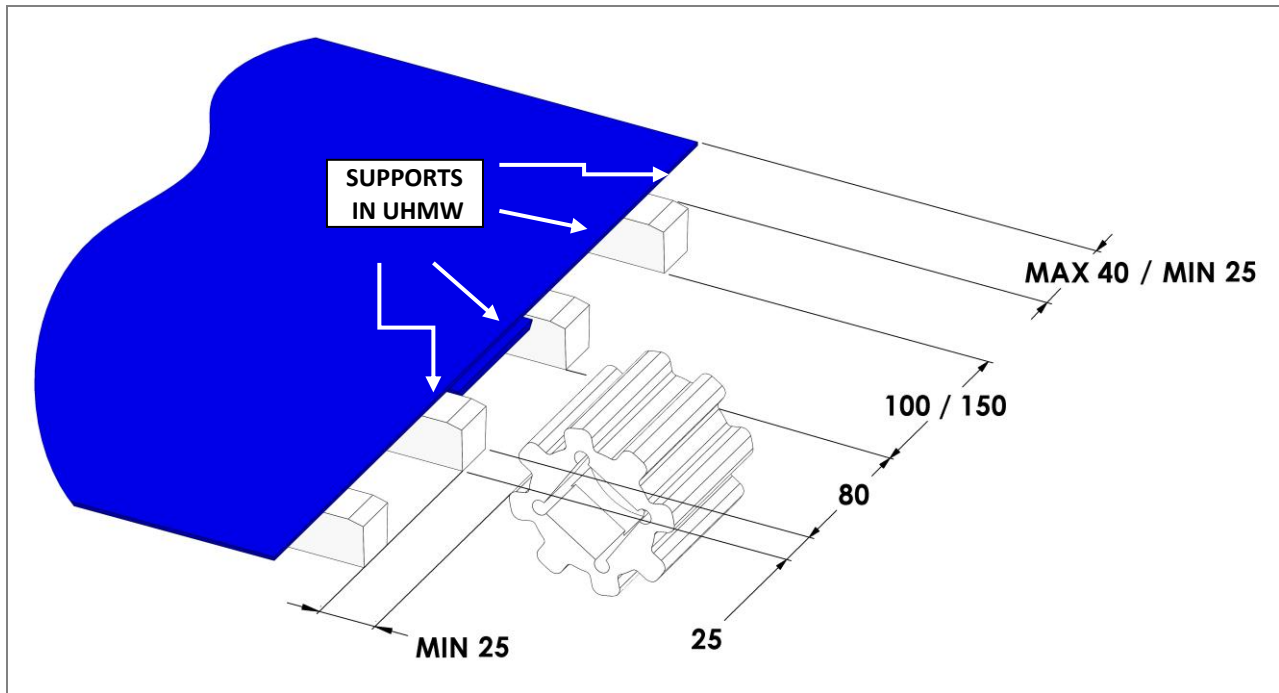

Fig. 5

The central supports must be positioned with 80mm internal distance. The supports should have a recommended standard width of 25 mm. They must be positioned with about 100-150mm pitch between each other, leaving a maximum distance of 40 mm from the edge.

#### 3.2.1 INSTALLATION AND POSITIONING OF THE SUPPORT PULLEYS

- The surface supported by pulleys should cover about 10% of the total width of the belt.

Example:

- Belt width	W = 500mm
- No.1 toothed pulley	C = 80mm
- Free width	F = W - C = 420mm
- Supports width	I = 20mm
- Number of supports =	$F * 10\% / I = (420 * 10\% / 20) = 2.1$

The result must be rounded off to the next closest whole number in order to maintain the symmetry = 2 supports.

- For belts with two toothed profiles, it is recommended to include at least one supporting pulley every two drive pulleys.
- The support pulleys must be added according to the weight to be carried and to the width of the belt. The support pulleys must be positioned in order to eliminate depressions on the surface of the belt; the maximum distance that may exist between pulleys is 150 mm.

**Examples of correct positioning of the support pulleys:**

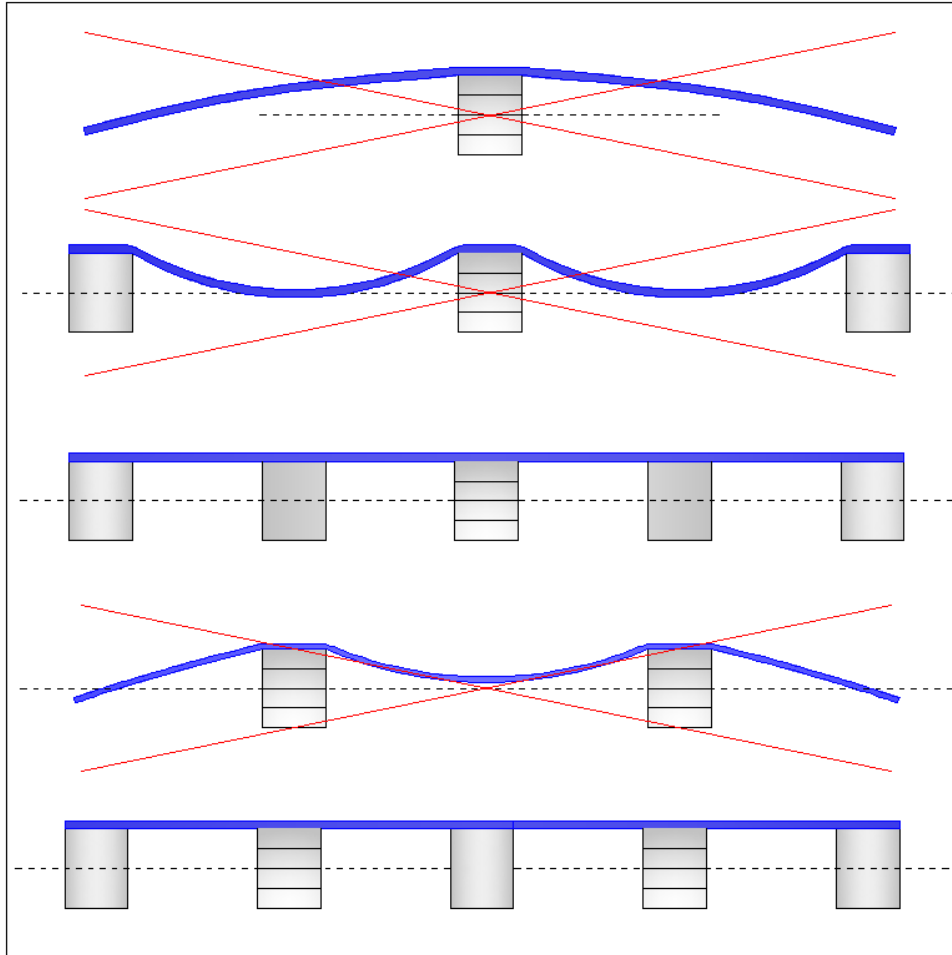

Fig. 6

*To eliminate depression at the sides of the two pulleys it is sufficient to insert one or more support pulleys to the sprocket sides so that the surface supported by the pulleys is equal to at least 10% of the belt width.*

*Always maintain the symmetry between the support pulleys.*

### 3.2.2 SUPPORT PULLEYS

It is essential to avoid slackening around the drive pulley, since this would prevent the toothed profile of the belt engaging with the drive pulley during operation. The distance between the return pulleys should support the weight of the belt in order to avoid slackening around the drive pulley.

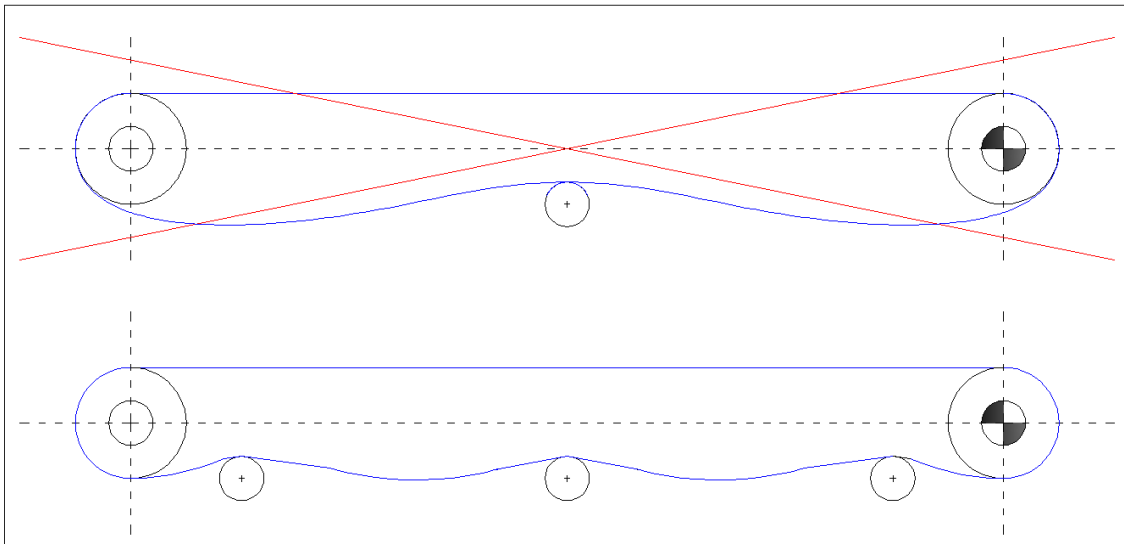

Fig. 7

The use of contrast pulleys increases the surface in contact with the drive pulley, thus reducing the chances of belt displacement under heavy loads. We recommend the use of contrast rollers when working with heavy loads or when the belt is running without tension. The purpose is to prevent slack around the drive pulley.

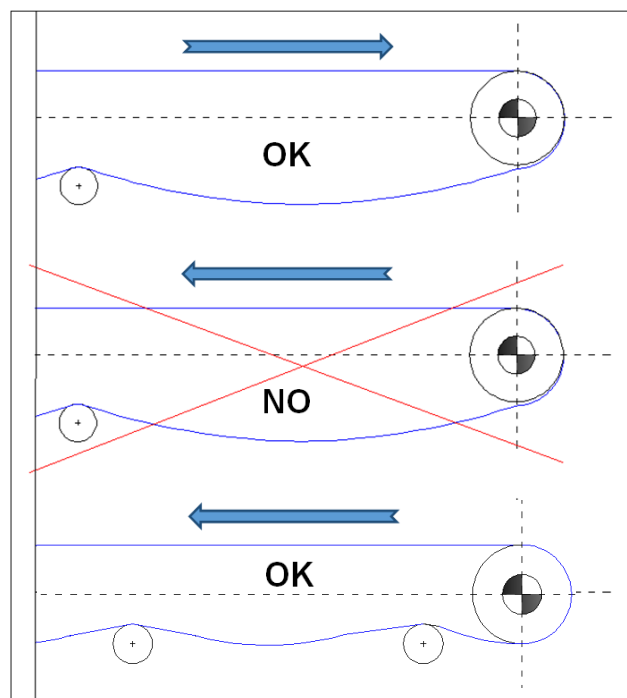

Fig. 8

### 3.2.3 STANDARD BELT TENSIONERS

The optimum operating tension for HP COMPACT DRIVE® belts should be  $\leq 0.2\%$  of elongation.

The tensioner has two functions:

- 1° To facilitate the assembly and fastening of the belt, if necessary;
- 2° To make the belt cleaning easier thanks to its predisposition for quick release.

Opening of the quick release tensioner allows slack between the belt and pulleys, facilitating cleaning.

The length of the belt tensioner and its structure depends on a number of factors:

- Length of the conveyor;
- Cleaning method;
- Structure of the conveyor.

We recommend an extension of at least 130-200 mm.

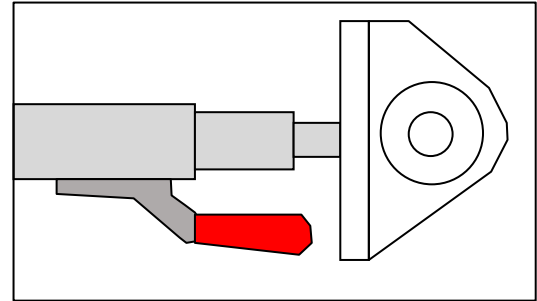

Fig. 9

### 3.2.4 QUICK RELEASE TENSIONERS

The quick release tensioner keep the belt tension constant when, after releasing the belt for cleaning, the tensioner returns to its original position.

The belt can be raised to provide easy and effective access to the underside of the belt, to the supports and pulleys for cleaning.

When finished, close the quick release tensioner to return the belt to its correct position and alignment, without need for further adjustments.

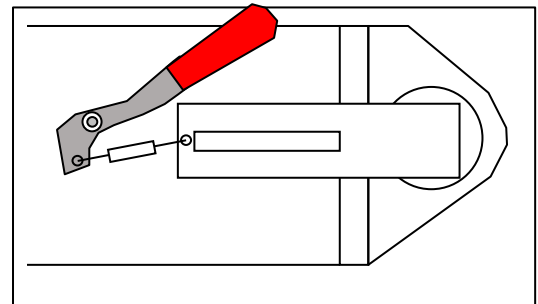

Fig. 10

### 3.3 CONVEYOR ADJUSTMENT

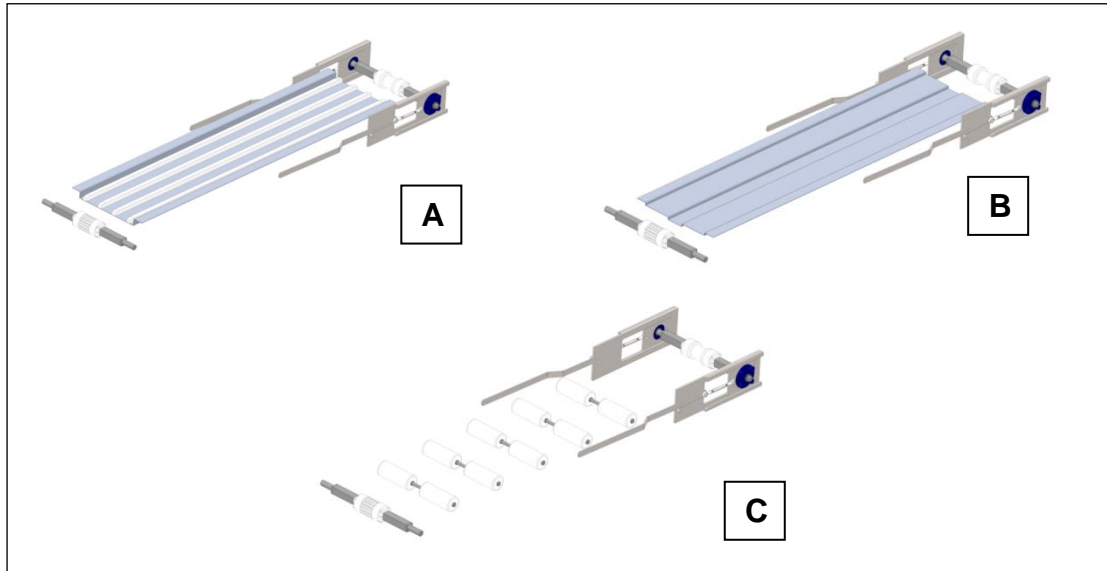

Fig. 11

#### 3.3.1 CONVEYOR WITH FLAT OR SUPPORTED SLIDEBED ADJUSTMENT

These conveyors typically have external sidewalls to convey the product. In this case, the supports do not act as a guide of the toothed profile of the belt.

The UHMW supports reduce the coefficient of friction between the belt and the slidebed (A).

The toothed profile may slide on the slidebed with the addition of a suitable groove (B), the belt operation is more regular and efficient.

This increases the load that the belt is able to convey, however, it may be necessary to change the arrangement of the drive and return pulleys.

#### 3.3.2 CONVEYOR WITH ROLLER SLIDEBED ADJUSTMENT

This type of conveyor (C) is not normally used for the food conveying. If you wish to install the HP COMPACT DRIVE® belts on a conveyor with roller slidebed, it is necessary to use the grooved rollers to guide the toothed profile of the belt and thereby provide for smooth operation of the belt.

### 3.4 "Z" OR "SWAN NECK" CONVEYOR CONSTRUCTION

The "Z" or "swan neck" conveyor is commonly used for the lifting of products from a lower to a higher level.

The HP COMPACT DRIVE® belts are ideal for this type of conveying for several reasons:

- They have a higher transversal stiffness, they do not fold in the centre when the direction of the belt changes from horizontal to inclined;
- They work without tension, thereby eliminating any problems of keeping the belt in place. The change of direction (from horizontal to angled) can be achieved using a roller or a series of small rollers (see image below).

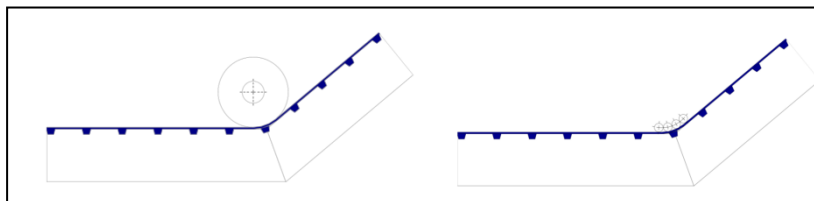

Fig. 12

- The diameter of the transition roller should be as large as possible and not inferior to the minimum diameter of the pulleys of the HP COMPACT DRIVE® belts; in case of more than one roller the diameter may be smaller;
- For belt widths of 800 mm or more, it is recommended to use guides on both sides in the upper part of the belt. The belt guides pass through the pulleys in "V" in the transition section to hold the belt;
- When using wide belts it is very important to support the belt on the return side. The presence of central profiles may cause issues and it may be necessary to install them two at a time in order to allow to support the belt.

### 3.5 CENTRE DRIVE CONVEYOR

This type of conveyor is normally used for bi-directional belts.

In this type of conveyor one may use a large diameter drive pulley in which the drive system is located and small pulleys on the sides of the conveyor, considering the narrow passage between them.

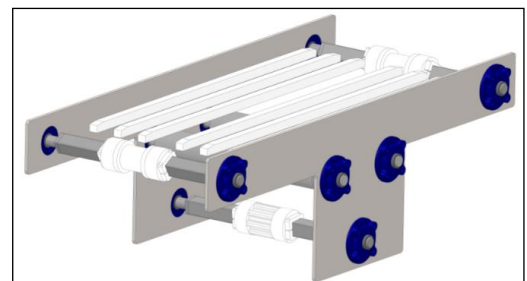

Fig. 13

### 3.6 BELT REMOVAL FOR CLEANING

Options in the conveyor construction that allow the removal of the belt:

- Quick release tensioner (ref. para. 3.2.4);
- Quick release plastic hinge (ref. chapter 5)



## 4. SIDEWALLS AND TRANSVERSAL PROFILES

### 4.1 HP SIDEWALLS

Code	Type	Dimensions (Fig. 14)			Material	Hardness Sh A	Thickness mm	Min. diameter <sup>1</sup> mm
		Pitch A mm	Width B mm	Height C mm				
ES-707	C-U 10/20 HP blue	24	22	20	TPU HP®	85	1.6	50
ES-708	C-U 10/30 HP blue	24	22	30	TPU HP®	85	1.6	70
ES-709	C-U 10/40 HP blue	24	22	40	TPU HP®	85	1.6	100
ES-710	C-U 10/50 HP blue	24	22	50	TPU HP®	85	1.6	120
ES-711	C-U 20/60 HP blue	50	42	60	TPU HP®	85	1.6	150
ES-712	C-U 20/80 HP blue	50	42	80	TPU HP®	85	1.6	190
ES-763	C-U 20/40 HP Compact blue	40	42	40	TPU HP®	85	2.7	100
ES-762	C-U 20/50 HP Compact blue	40	42	50	TPU HP®	85	2.7	120
ES-764	C-U 20/60 HP Compact blue	40	42	60	TPU HP®	85	2.7	145
ES-765	C-U 20/80 HP Compact blue	40	42	80	TPU HP®	85	2.7	200

Table 4

<sup>1</sup> Minimum pulley diameter referred to environment conditions of 20 °C

Fig. 14 shows a belt with sidewalls and transversal profiles, both with pitch 40 mm.

The advantages of 40 mm pitch sidewalls are:

- It is possible to synchronize the wave pitch with 40 mm pitch teeth.
  - It is possible to synchronize the pitch of the transversal profiles with the waves of the sidewalls.
- Note: The welding of the transversal profiles must be centred between one tooth and the next: this means that the pitch of the transversal profiles must be a multiple of the tooth pitch.
- The increased thickness of 2.7mm gives greater stiffness.

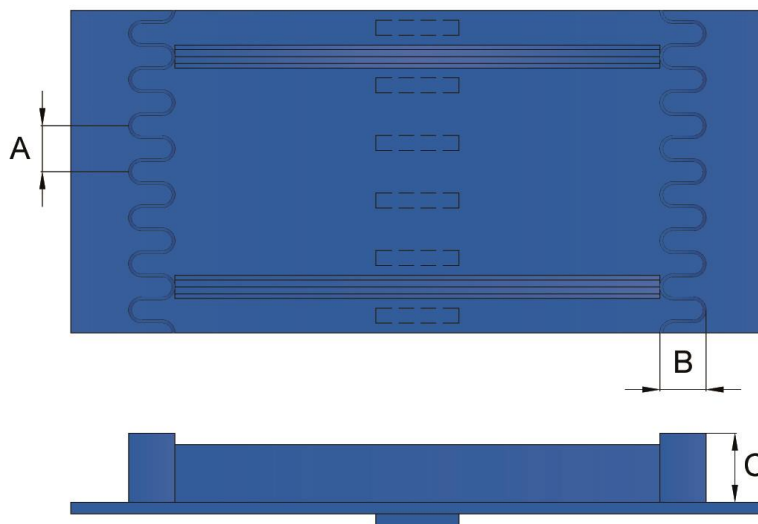



Fig. 14

## 4.2 **HP** TRANSVERSAL PROFILES

	Code	Type	Dimensions b x h mm	Material	Hardness Sh A / Sh D	Min. transversal pitch mm	Min. transversal diameter <sup>1</sup> mm
	ES-543	<b>L20 U HP blue</b>	10 x 20	TPU HP®	70 Sh A	40	40
	ES-546	<b>L30 U HP blue</b>	10 x 30	TPU HP®	70 Sh A	40	40
	ES-549	<b>L40 U HP blue</b>	10 x 40	TPU HP®	70 Sh A	40	40
	ES-535	<b>L50 U HP blue</b>	10 x 50	TPU HP®	70 Sh A	40	40
	ES-538	<b>L80 U HP blue</b>	10 x 80	TPU HP®	70 Sh A	40	40
	ES-731	<b>L80 U HP blue 55D</b>	10 x 80	TPU HP®	55 Sh D	40	40
	ES-563	<b>T20 U HP blue</b>	10 x 20	TPU HP®	70 Sh A	40	40
	ES-560	<b>T30 U HP blue</b>	10 x 30	TPU HP®	70 Sh A	40	40
	ES-557	<b>T40 U HP blue</b>	10 x 40	TPU HP®	70 Sh A	40	40
	ES-554	<b>T50 U HP blue</b>	10 x 50	TPU HP®	70 Sh A	40	40
	ES-534	<b>T60 U HP blue</b>	10 x 60	TPU HP®	70 Sh A	40	40
	ES-713	<b>T50 U HP blue 55D</b>	10 x 50	TPU HP®	55 Sh D	40	40

*Table 5*

<sup>1</sup> Minimum pulley diameter referred to environment conditions of 20 °C

## 5. ENDLESS MAKING

HP COMPACT DRIVE<sup>®</sup> belts can be made endless as follows:

- **On-site Micro-Z finger joint**
- **Mechanical Fastener APF-100**
- **Mechanical Fastener HY-FAST™**

### 5.1 ON-SITE MICRO-Z FINGER JOINT

The joint size is fixed at 12 mm x 6 mm, to allow its creation within the existing space between the drive teeth.

There are 4 different ways to make it:

- a. Ordering the belt pre-prepared by Chiorino Biella;
- b. Using an automatic cutting table;
- c. By means of a cut "on site" using a F700M finger puncher for widths up to of 1200 mm (see figure 15) based on the punching plate used;
- d. It is also possible to create the joint using a special adhesive belt in order to achieve the required fastener size 12 x 6.

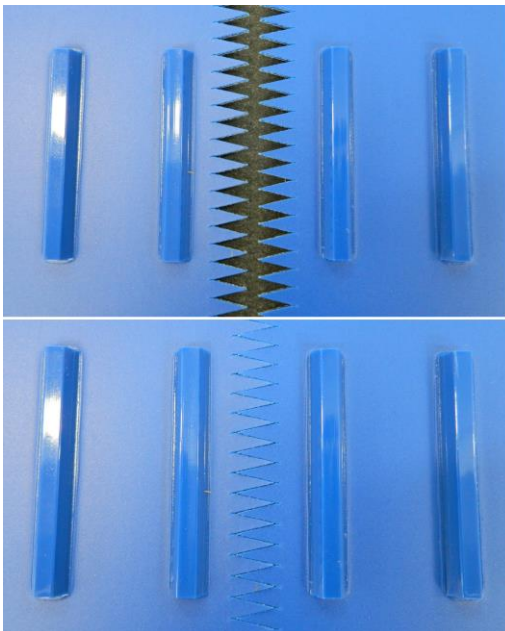

Fig. 15

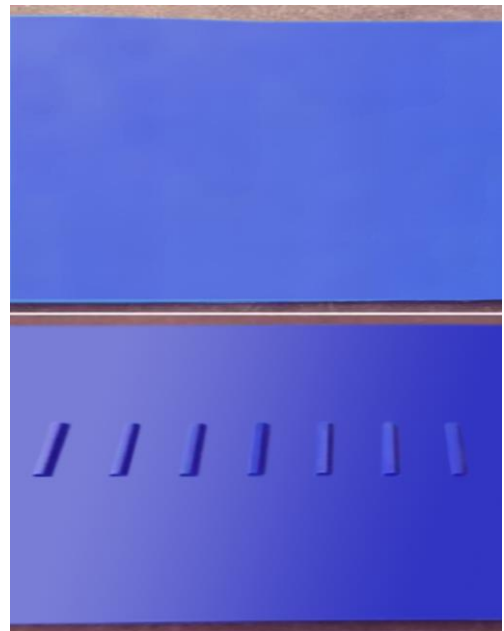

Fig. 16

## 5.2 MECHANICAL FASTENER APF-100

The plastic mechanical fastener APF-100 can be applied directly on the belt by the simple use of a portable kit for installation.

### Benefits

- Easy installation
- Facilitates disassembly and belt cleaning
- Total absence of metal parts

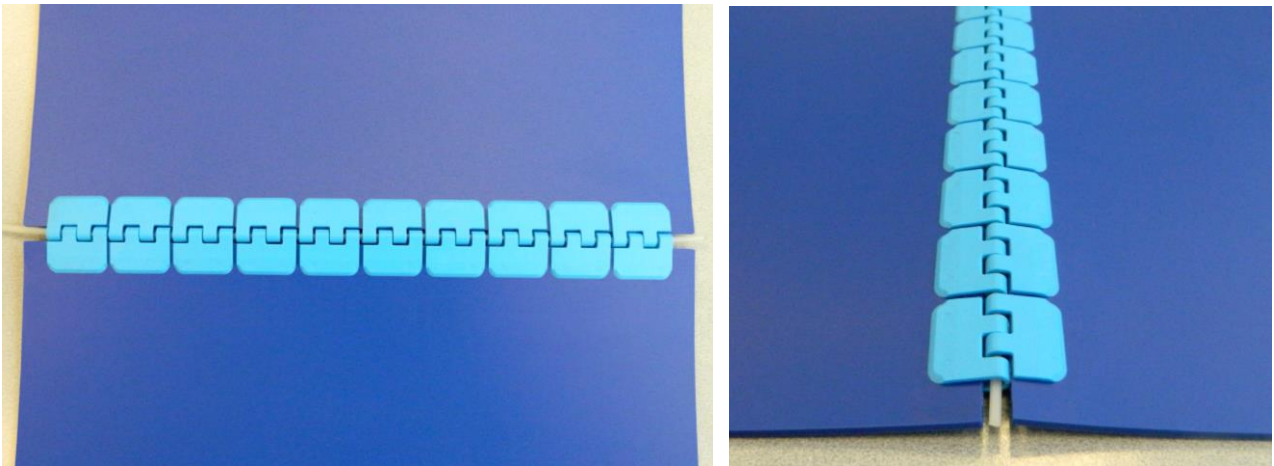

Fig. 17

*APF-100 is not recommended in presence of scrapers.*

### 5.3 *HY-FAST*<sup>™</sup> HYGIENIC MECHANICAL FASTENER



The *HY-FAST*<sup>™</sup> mechanical fastener allows the removal of the conveyor belt, making daily cleaning and maintenance operations very easy.  
The opening of the fastener is done by the extraction of **two transparent sealing pins** made of a **food compliant plastic material**.

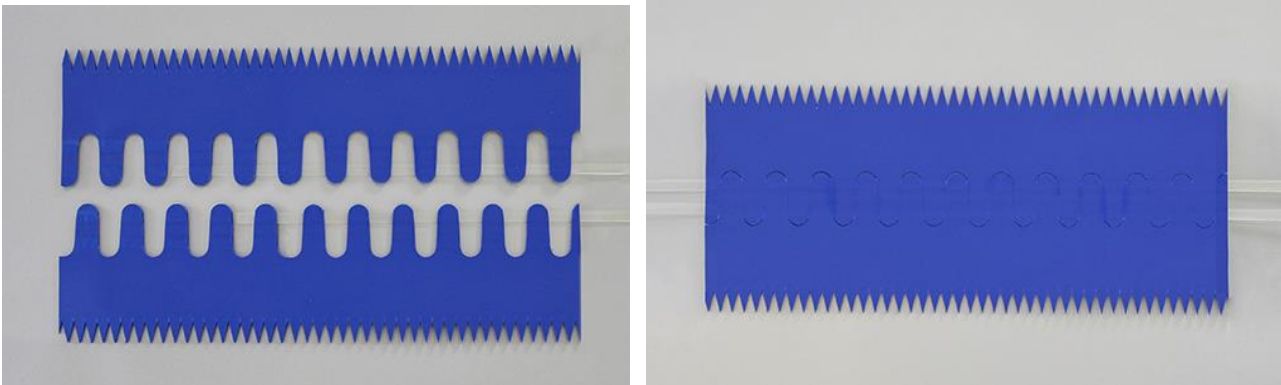

Fig. 18

#### Benefits

- Ease of disassembly and cleaning through the removal of the sealing pins

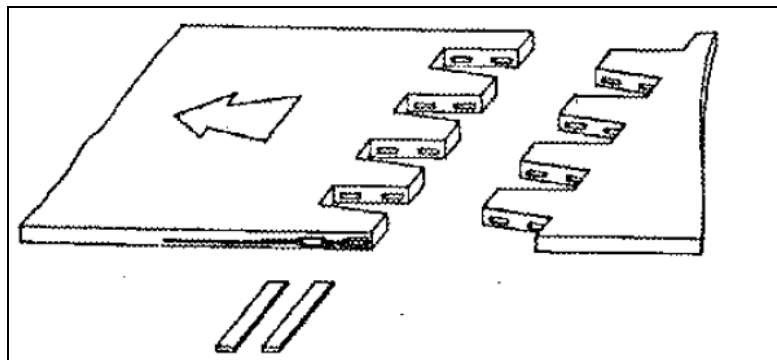

Fig. 19

- Total absence of metal parts
- Tightness and flatness of the fastener, ideal for the food environment.

*HY-FAST*<sup>™</sup> is not recommended in presence of scrapers.

## 6. BELT CALCULATION

The following chapter will aid correct calculation of the HP COMPACT DRIVE® belts.

The maximum conveyable load on the belt varies as a function of the following parameters:

- The degree of inclination of the conveyor [°]
- Belt width [mm]
- Length of the conveyor section [mm]

## 6.1 BELT CALCULATION FOR HORIZONTAL CONVEYING

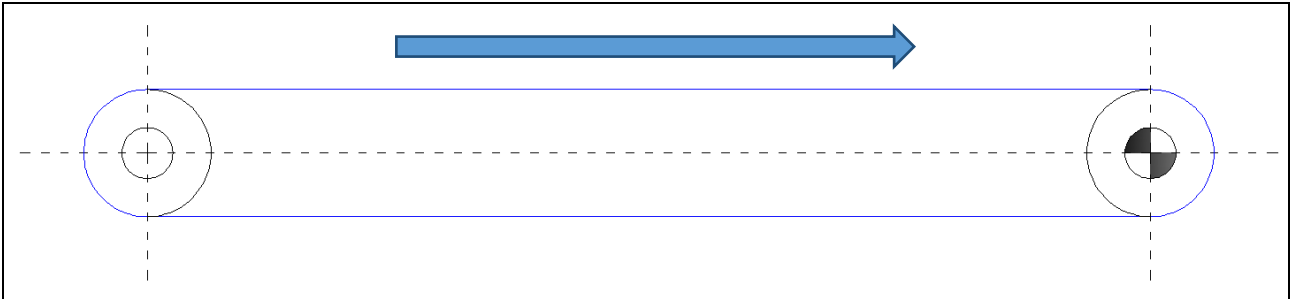
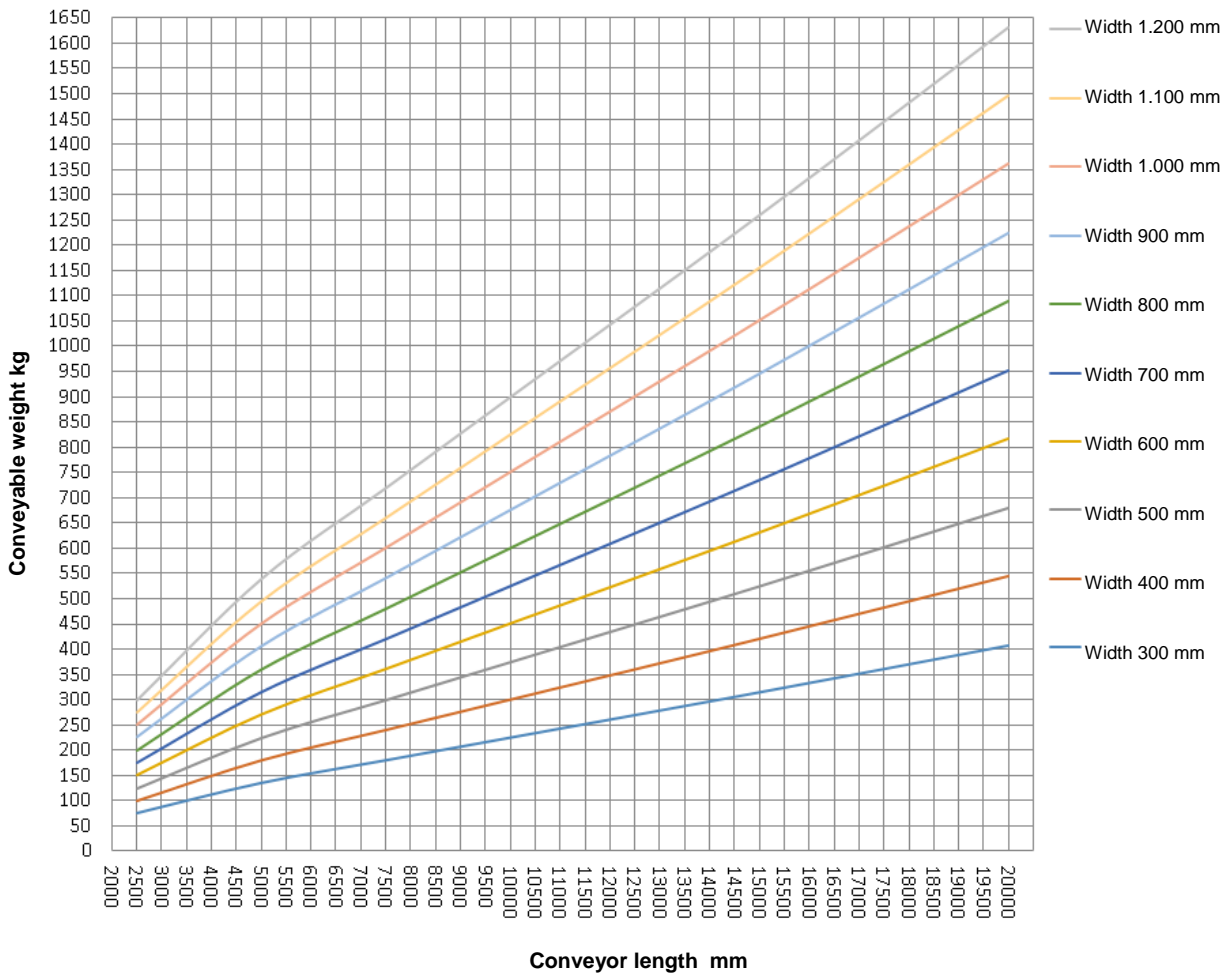

Fig. 20





## 6.2 BELT CALCULATION FOR 10° INCLINATION CONVEYING

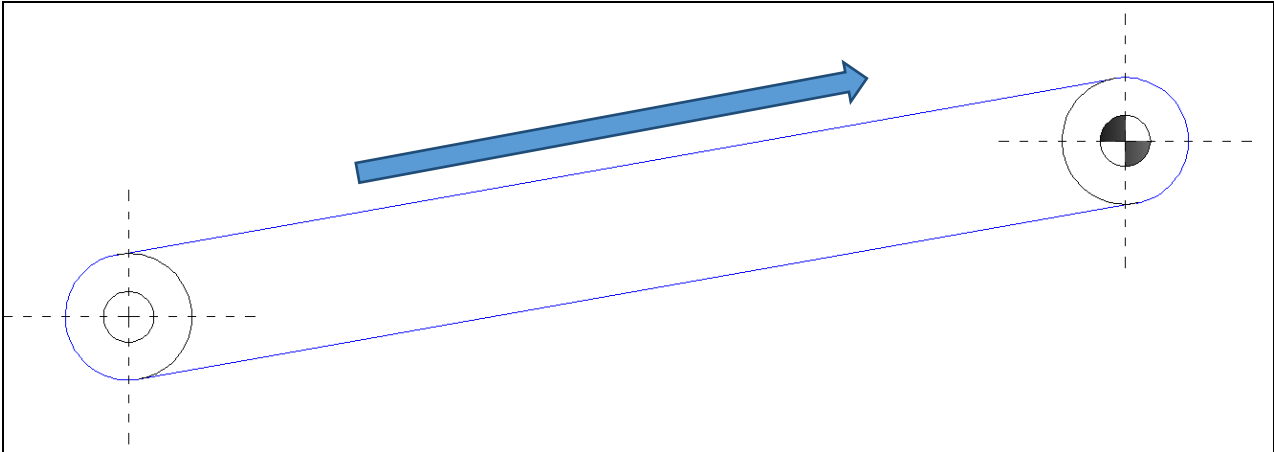
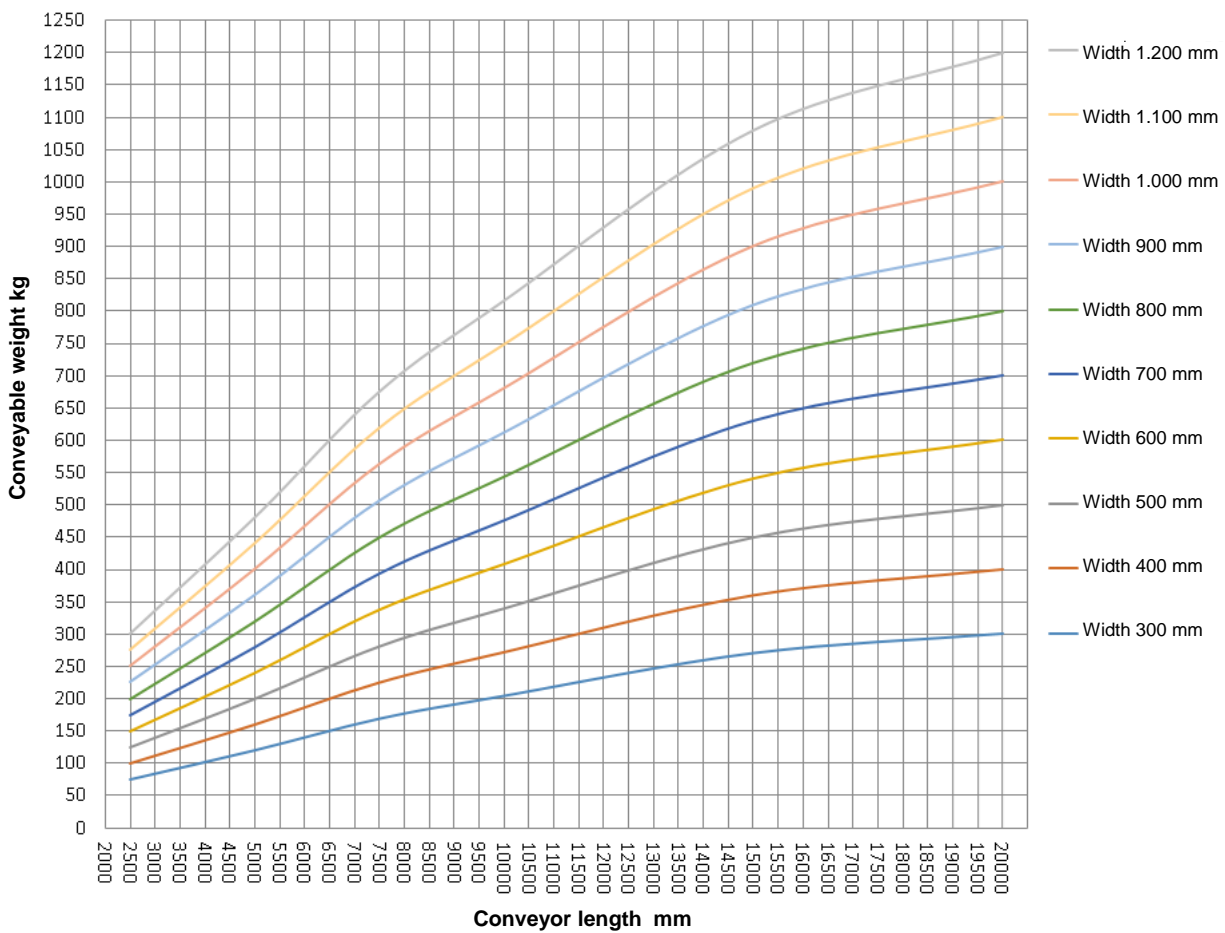

Fig. 21



### 6.3 BELT CALCULATION FOR 20° INCLINATION CONVEYING

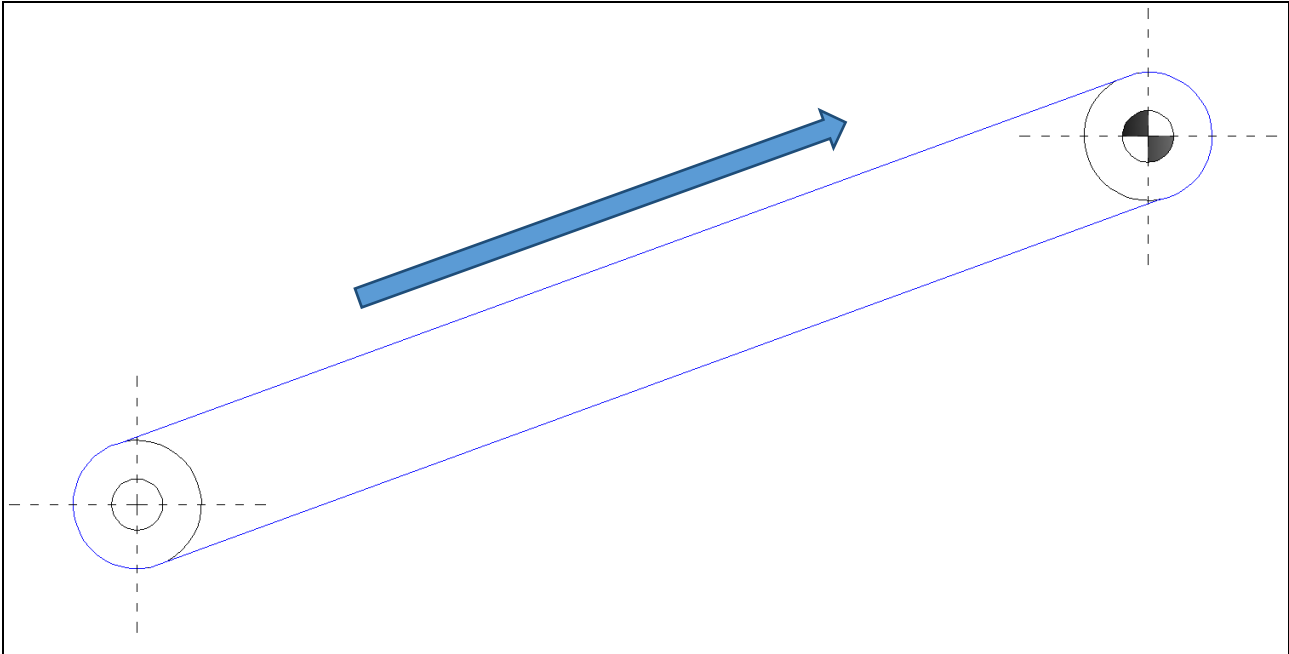
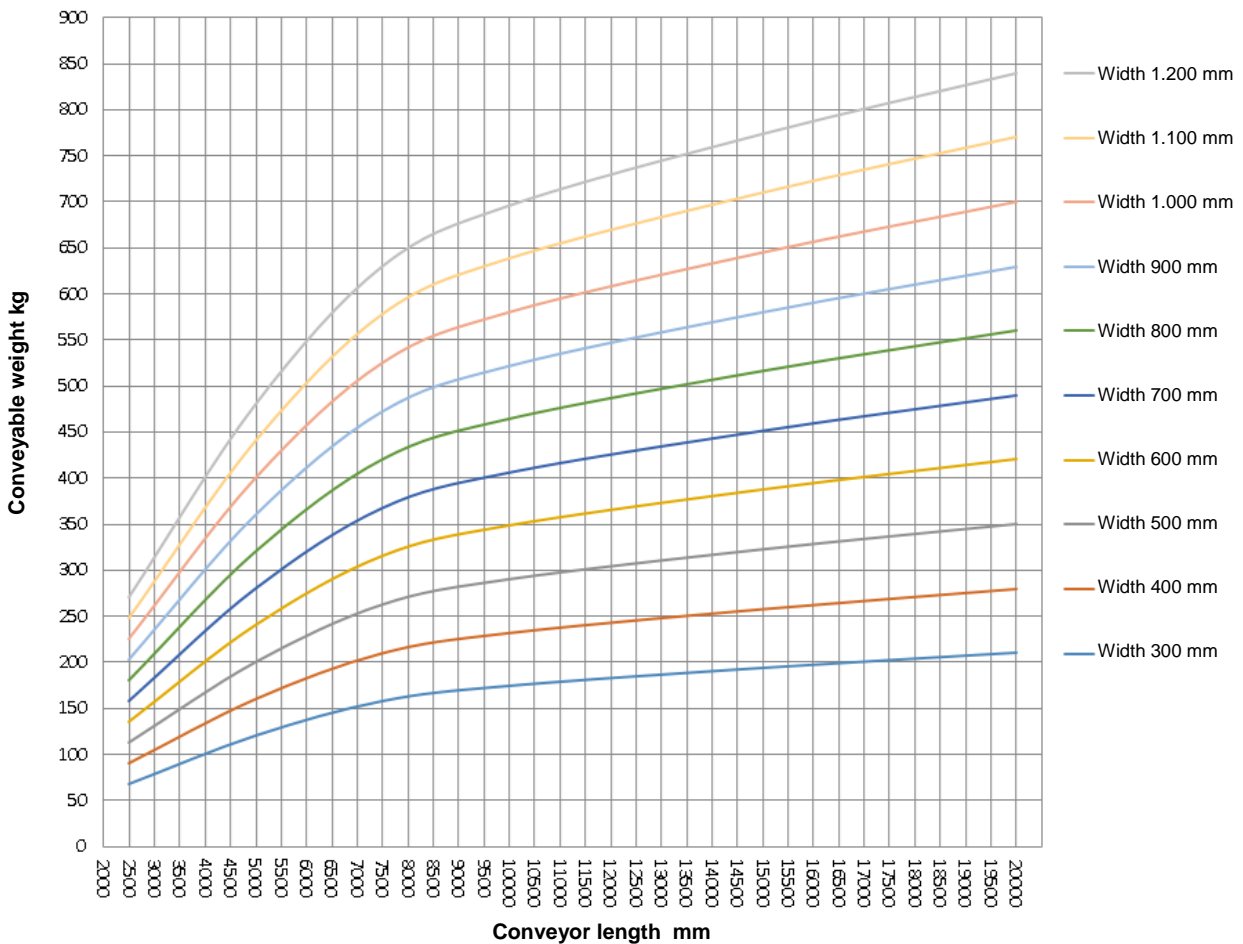

Fig. 22



### 6.4 BELT CALCULATION FOR 30° INCLINATION CONVEYING

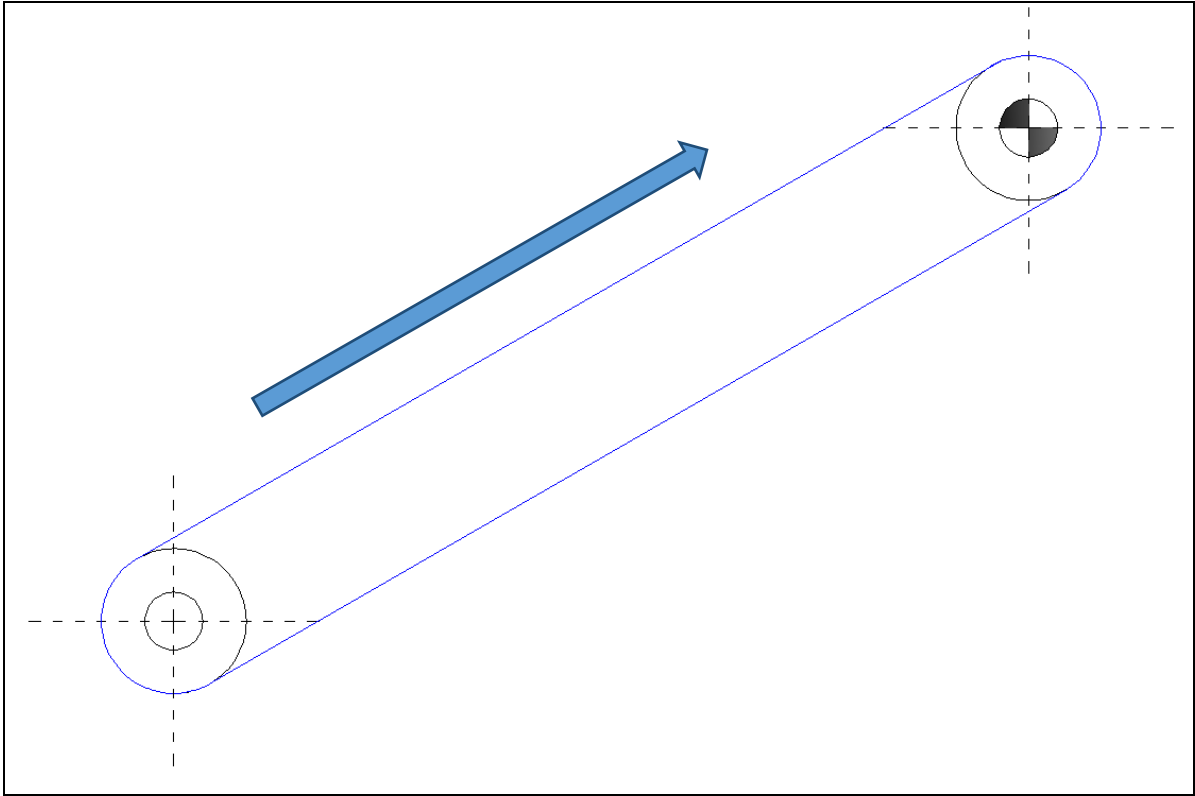
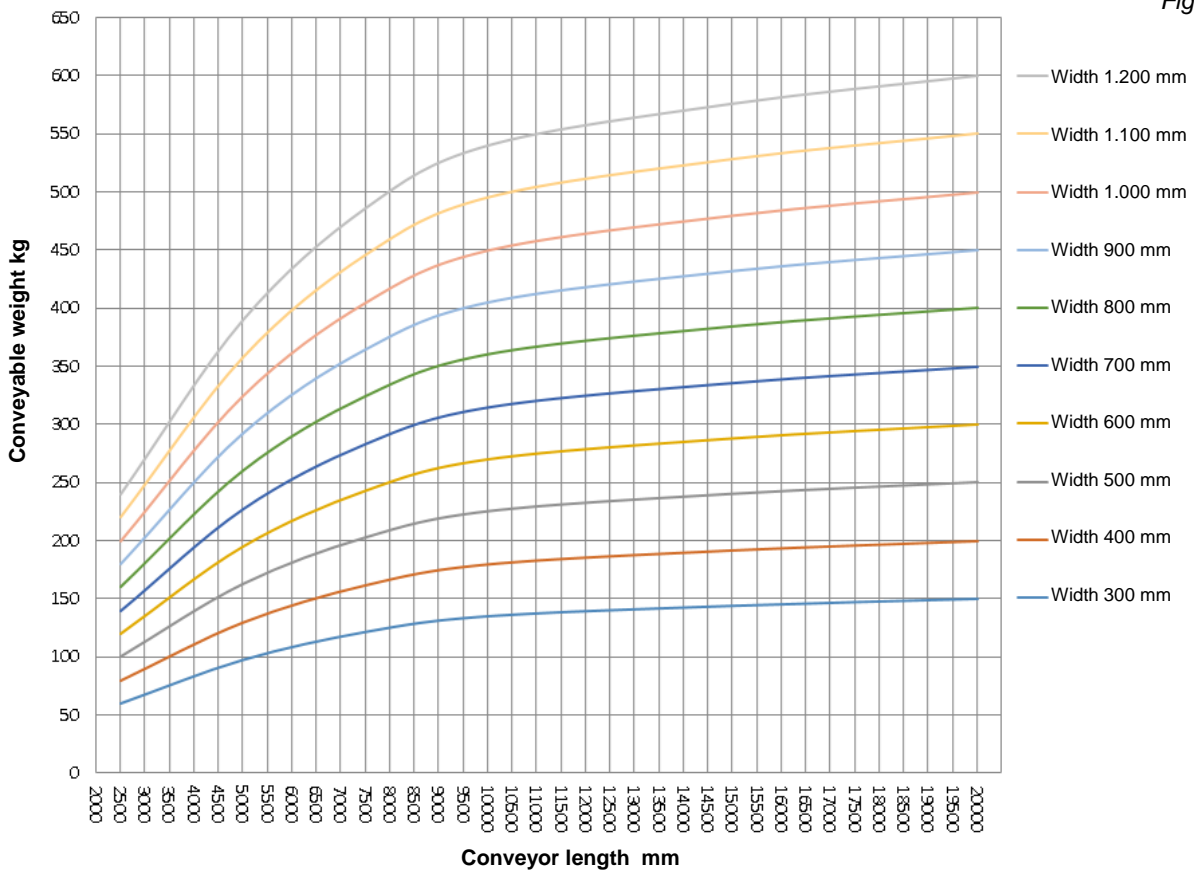

Fig. 23



### 6.5 BELT CALCULATION FOR 40° INCLINATION CONVEYING

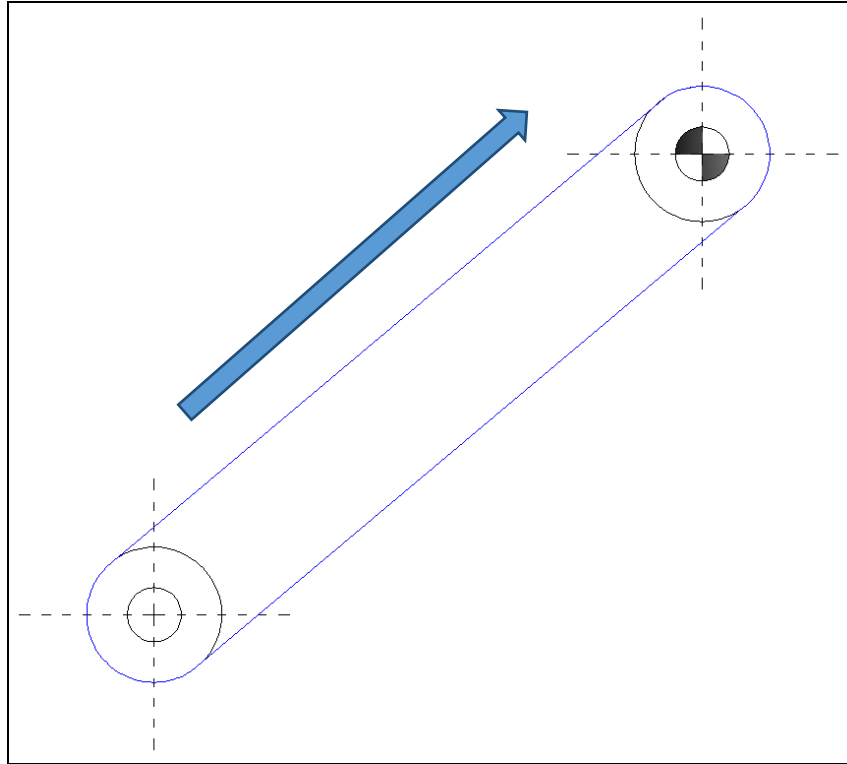
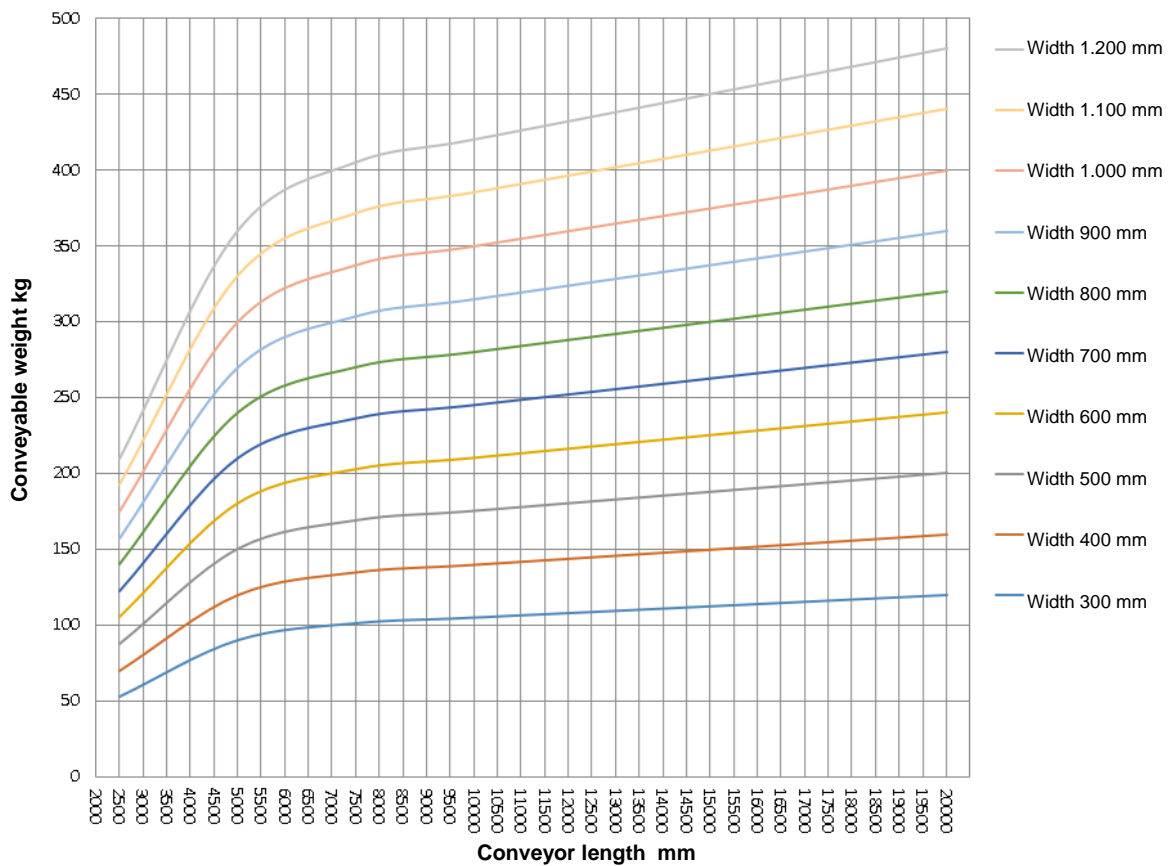

Fig. 24



## 6.6 EXAMPLE OF CALCULATION

Suppose we need to calculate a belt under these conditions:

- Degree of inclination = 10°
- Belt's width = 500 [mm]
- Length of conveyor section = 10,500 [mm]

To obtain the maximum conveyable load it is necessary to interpolate the data available in the graph below:

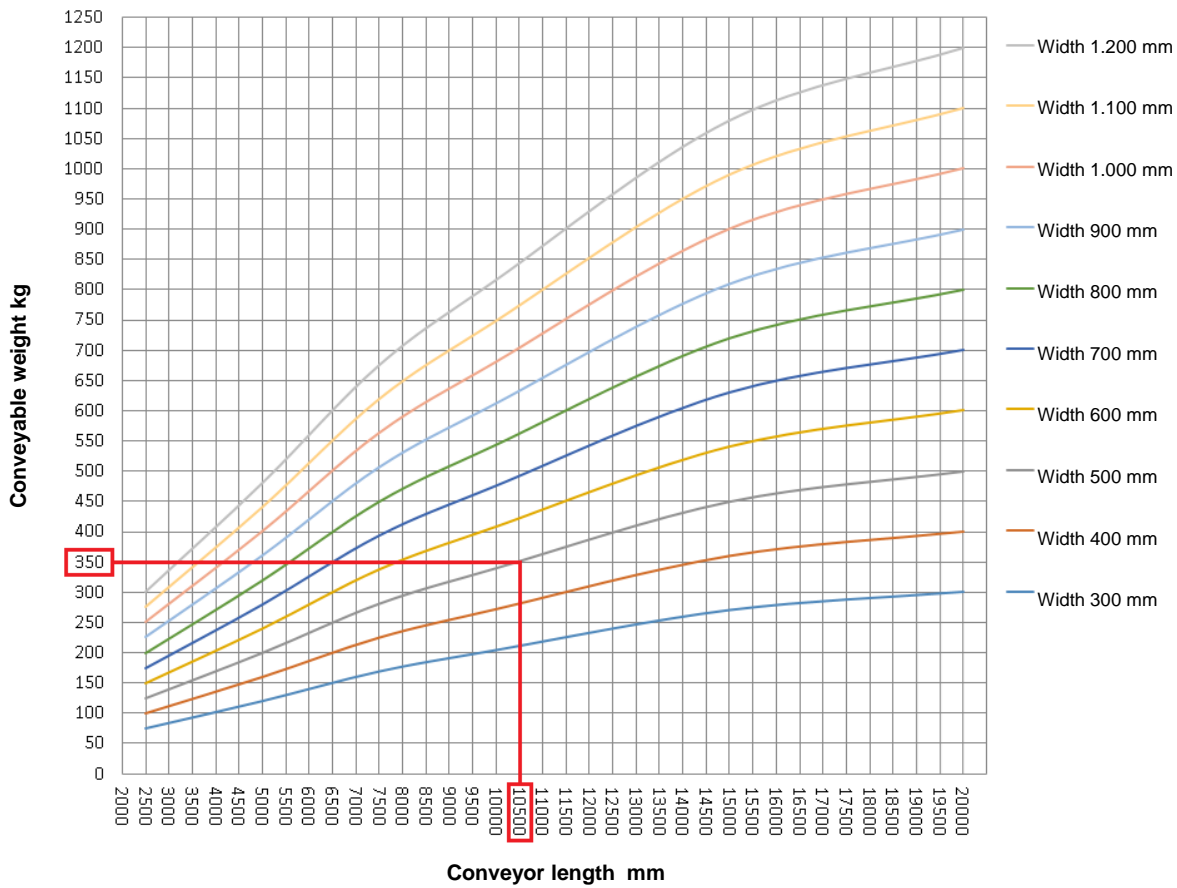

The maximum conveyable load in these conditions is equivalent to 350 kg.

Shall it be necessary to set a belt with a width greater than 1200 mm contact Chiorino Technical Service.

*When calculating, the load values are considered to be evenly distributed across the conveyor surface.*

## 7. MAINTENANCE AND CLEANING

### 7.1 MAINTENANCE

It is recommended to control periodically the tension of the belt in case the belt is involved in critical working conditions:

- Start up at full load.
- Temperature variation.

It is important to maintain clean all the elements of the conveyor in contact with the belt as the presence of dirt, traces of product, oil, grease, moisture and rust could cause malfunction and shortening the useful working life of the belt.

### 7.2 CLEANING

The cleaning of the belt is of fundamental importance to maintain the correct tracking, the right pulling of the belt and its performance (life). Hygiene is very important in the food industry where special cleaning operation are always in place.

Some aspects related to cleaning of HP COMPACT® series:

- Cleaning must be performed on the stationary conveyor: safety condition.
- In case of soiling (dust, etc.), cleaning the belt with a soft cloth dry or lightly moistened with cold or warm water.
- The oily or greasy dirt can be removed using warm water and generic nonabrasive detergent (the little foamy detergents facilitate rinsing).
- The coarse dirt can be removed by wiping with warm soapy water, or washing with a delicate solvent (Table - 6).
- Solvents such as aromatic compounds, chlorinated hydrocarbons and ketones are unsuitable for cleaning.
- If you are working in the presence of flammable chemicals, comply with all safety measures in force.

Admissible detergents - The table here below reports the compatibility of the detergents with the cleanliness of HP COMPACT® belts:

Type of detergent	Example	Compatibility
Neutral	Water	Yes
Basic	Solution of water & soap, sodium hydroxide and ammonia	No
Acid	Acetic acid, Citric acid	Yes
Chlorinated	Sodium hypochlorite	No
Alcoholic	Ethanol, Methanol, commercial alcohol	No

Table 6

## Installation Questionnaire

	DATA	NOTES
<b>CONVEYOR</b>		
<b>OEM / Check Nameplate</b>		
<b>Belt size</b>		
<b>Speed [m/min]</b>		
<b>Bed type:</b>		
<i>Wear Strips</i>		
Number across conveyor width		
Spacing		
Material		
<i>Slider bed</i>		
Material		
<i>Rollers</i>		
Number of rollers		
Spacing of rollers		
<b>Returnway: wear strip, rollers, stationary bar</b>		
<b>Conveyor sidewalls</b>	yes or no	
Fenders – height		
<b>Profiles</b>	yes or no	
Type and dimension		
<b>Trough conveying</b>	yes or no	
<b>Tail pulley diameter [mm]</b>		
<b>Conveyed material</b>		
<b>Total load on belt</b>		
<b>Inclined</b>	yes or no	
Angle of incline		
“Z” conveyor transition guide	yes or no	
<b>Tensioner</b>		
Type		
Total travel		
<b>PULLEYS</b>		
<b>Replacing existing pulleys?</b>	yes or no	
<b>Number of pulleys</b>		
<b>Number of teeth and diameter [mm]</b>		
<b>Square shaft</b>		
Dimension [mm]		



## CHIORINO AFFILIATED COMPANIES

### America

CHIORINO AMERICA  
Newark, DE  
Tel. +1-302-292-1906  
info@chiorino.us  
www.chiorino.us

### Australia

CHIORINO AUSTRALIA - Brisbane  
Tel. +61-7-3274 1900  
sales@chiorino.com.au  
www.chiorino.com.au

### Benelux

CHIORINO BENELUX B.V. - Utrecht,  
The Netherlands  
Tel. +31-30-2413060  
chiorino@chiorino.nl  
www.chiorino.nl

### Byelorussia

CHIORINO-K - Minsk  
Tel. +375-17-2804578  
general@chiorino.ru  
www.chiorino.ru

### China

CHIORINO ASIA Ltd.  
Hong Kong  
Tel. +852-397-10818  
info@chiorino.asia  
www.chiorino.asia

CHIORINO LIAISON OFFICE, Shanghai  
Tel. +86-21-37831019  
info@chiorino.cn  
www.chiorino.cn

### France

CHIORINO SAS - Lagny, Paris  
Tel. +33-1-64304075  
chiorino.paris@chiorino.fr  
www.chiorino.fr

### Germany

CHIORINO GmbH - Mainz  
Tel. +49-(0)6131-55449-0  
info@chiorino.de  
www.chiorino.de

### Hungary

CHIORINO Kft. - Szigetszentmiklós,  
Budapest  
Tel. +36-24-525930  
mail@chiorino.hu  
www.chiorino.hu

### India

CHIORINO INDIA - Salcete Goa  
Tel. +918-322-782454  
info@chiorino.in  
www.chiorino.in

### Italy

CHIORINO PARMA s.r.l. - Parma  
Tel. +39-0521-292236  
chiorinoparma@chiorino.com

CHIORINO VENETO s.r.l. - Colle Umberto  
Tel. +39-0438-430460  
chiorinoveneto@chiorino.com

### Poland

CHIORINO Sp. z o.o. - Bydgoszcz  
Tel. +48-(0)52-3487708  
chiorino@chiorino.com.pl  
www.chiorino.com.pl

### Portugal

CHIORINO PORTUGAL, LDA  
Alfena Valongo, Porto  
Tel. +35-122-9684442  
geral@chiorino.pt  
www.chiorino.pt

### Romania

CHIORINO srl - Cluj Napoca  
Tel. +40-264-432977  
chiorino@chiorino.ro  
www.chiorino.ro

### South Africa

CHIORINO SOUTH AFRICA (PTY) LTD.  
Johannesburg  
Tel. +27-11-3971268  
sales@chiorino.co.za  
www.chiorino.com

### Spain

CHIORINO IBERICA S.A. - Rubí, Barcelona  
Tel. +34-93-5860480  
chiorino@chiorino.es  
www.chiorino.es

### Switzerland

CHIORINO SCHWEIZ GmbH - Wetzikon  
Tel. +41-(0)43-3116001  
info@chiorino.ch  
www.chiorino.ch

### United Kingdom

CHIORINO U.K. Ltd. - Featherstone  
Tel. +44-1977-691880  
sales@chiorino.co.uk  
www.chiorino.co.uk

## CHIORINO DISTRIBUTORS

Albania  
Argentina  
Armenia  
Austria  
Azerbaijan  
Bangladesh  
Belgium  
Bolivia  
Bosnia-Herzegovina  
Botswana  
Brazil  
Bulgaria  
Cambodia  
Canada  
Chile  
Colombia  
Costa Rica  
Croatia  
Cyprus  
Czech Republic  
Denmark  
Egypt  
Estonia  
Fiji  
Finland  
Georgia  
Greece  
Guatemala  
Honduras  
Iceland  
Indonesia  
Iran  
Ireland  
Israel  
Ivory Coast  
Jordan  
Kazakhstan  
Kenya  
Kirgystan  
Laos  
Latvia  
Lebanon  
Lithuania  
Macedonia  
Malawi  
Malaysia  
Mexico  
Moldova  
Morocco  
Myanmar  
New Caledonia  
New Zealand  
Nicaragua  
Pakistan  
Panama  
Papua New Guinea  
Paraguay  
Peru  
Russia  
Saudi Arabia  
Serbia  
Slovak Republic  
Slovenia  
South Korea  
Sri Lanka  
Sweden  
Tadjikistan  
Thailand  
Turkey  
Turkmenistan  
Ukraine  
United Arabian Emirates  
Uzbekistan  
Vietnam  
Yemen  
Zimbabwe

## HEADQUARTERS AND PRODUCTION PLANTS

### CHIORINO S.p.A.

Via S. Agata, 9  
I-13900 Biella, Italy  
Tel. +39 015 8489 1  
Fax +39 015 849 61 61  
chiorino@chiorino.com  
www.chiorino.com

UNI EN ISO 9001:2015  
UNI EN ISO 14001:2015  
OHSAS 18001:2007  
EMAS



ENGINEERING ADVICE  
ON-SITE INSTALLATION SERVICE  
AFTER SALES SUPPORT

